

## PLC CENTRALIZATION TECHNICAL ALARMS with text display

Warranty  
2 years  
Warranty



Multicolored LEDs

MADE IN  
**FRANCE**



«LEDs test» button   «Reset» button   Text screen   Setup

DIN 144 x 144 format



### FUNCTION :

The setting can be done from the front with the text screen, or by PC with free software in several languages. Parameters are storable on hard drive, printable and duplicable.

The RESET is possible «channel by channel» with an external push button on each input (see manual start-up).



The J3500 is a PLC of technical alarms treatment, integrating all the functions required for local or deported signaling. It has been designed for easy adaptation to all possible figure configurations likely to be encountered.

Numerous complementary functions have been added to those already present on the J3000/J3105. The multilingual text screen (3 languages) allows easy the setting of each channel and can displaying the historic of alarms. A luminosity adjustment system is available.

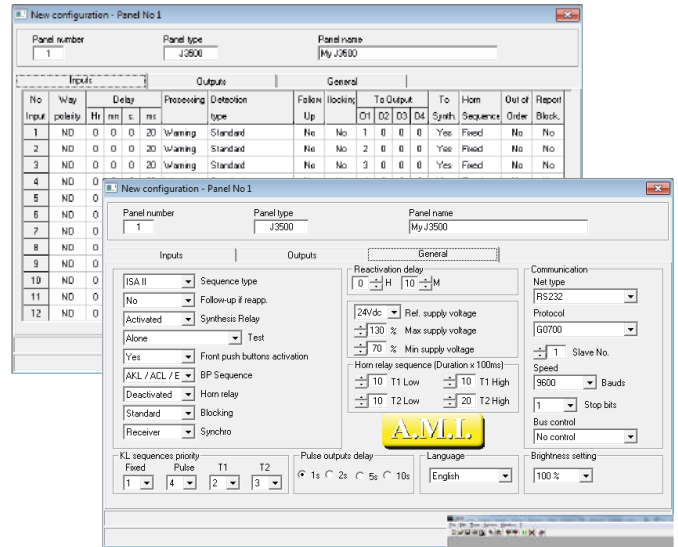

- Indicator (simple light) or Alarm treatment.
- Multiple types of sequences.
- Relaunch Alarm.
- Reactivation depending on input state.
- Global cancellation or per channel.
- Multiple types of sequences on RESET buttons and terminals.

12 «open collector» outputs

- «Contact outputs» possible.
- Association of 4 outputs possible on each input.
- Output synthesis selectable channel by channel.

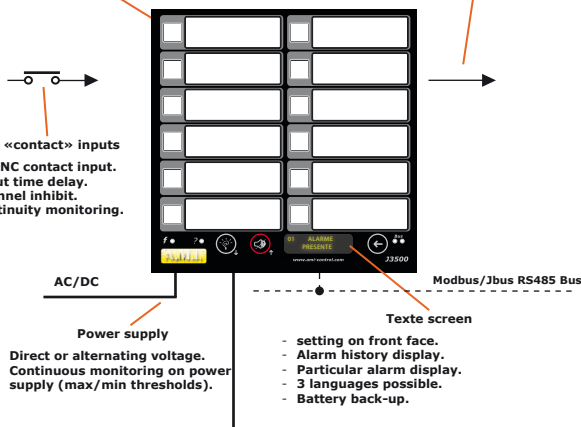

Free PC parametering software with recovery of the last 64 events

It includes the management of memorizations, blinkings and acknowledgement systems.

- Modular, installation can be extended to an infinite number of inputs.
- Flush mounting, it can be immediately integrate on the front of bay, on console or cabinet.

Its climate ambience tolerances (-10°C/+50°C) and its extended power supply range (direct and alternating current supply) makes it an essential component for any high-risk installation.

Technical Alarm

## FRONT VIEW :

- 12 unpluggable LEDs 10x10mm , high-luminosity . It's possible to change colours (red as standard, yellow, green, blue).
- Large label with 4 lines of text possible.
- LED indicator of «Power supply presence».
- LED «Alarm» indicator: BUS alarm / alarm of power supply level.
- «LEDs Test»/«Next» pushbutton.
- «Reset»/«Previous» pushbutton.
- Screen of 2 lines of 16 characters to show: History Alarms/Program. It allows to easily perform the settings with the front panel keys.
- Program/History pushbutton.
- LED indicator Transmission / Reception Bus.

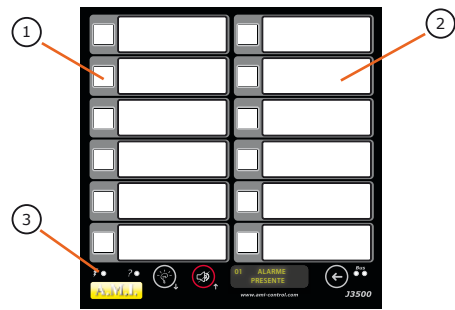

**Language :** The language used for menu texts can be selected in English, French or Spanish.

**History :** In normal mode the display panel can recall the previous 64 events. It shows the channel number and the type of event. This information are numbered and classified in arrival order. It is possible to delete the historic.

**Brightness adjustment :** For some special cases, it is possible to adjust the brightness of the LEDs and of the screen. This adjustment can be done from the front panel or by bus in program mode. (Example: navy applications).

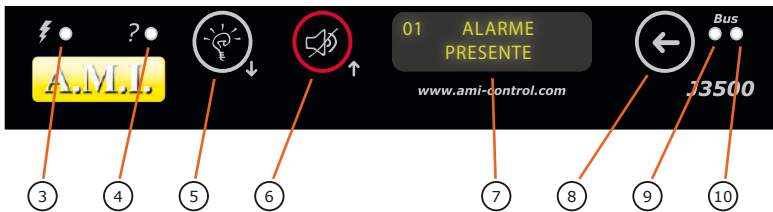

The J3500 is an alarm processing controller with 12 inputs, 12 LEDs and 12 outputs and an optional RS485 Bus.

It is modular, this allows :

- Just use the desired number of identical panels for performing an installation. Whatever of the number of entries or configuration, each local sub stations will be equipped with the same model of product. (Decrease in inventory, easier maintenance).
- Reduce the overall processing time (each panel manages its own inputs)
- Ability of create families of panels to obtain the first alarm on a subset.
- Security: in case of failure of one of them, the other panels will continue their control.



## PARAMETERING :

The different settings can be made :

- Directly from the front of the J3500 through a luminous display and user friendly menus..

Changes are made using the three buttons present. An access code is provided.

- On the screen of the PC, with free software. It allows you to prepare settings, and then load them into the J3500.

### Configuration from the front :

Since the front of the J3500, it is possible to set the entire J3500. A drop down menu appears on the text display for changing all parameters. Access to programming menu is protected by a changeable password.

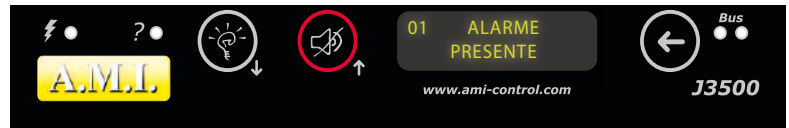

3 buttons on front panel allows moving the dropdown menu, displaying options and validating the choice.

Language: You can select the language on the text display: French, English, and Spanish.

Although simple to use, this setting is used for changes in local mode. The setting by PC offering many others advantages.

### Configuration from the software :

The software is free and available on our website.

It allows quick setup by selecting values on the screen.

The program consists of 3 different menus tabular form :

- The Inputs.
- The Outputs.
- The General parameters of the J3500.

This software allows you to create settings, store them on hard disk and print them. It also allows you to copy the settings present in an existing panel to modify and then reconfigure another panel.

**For details of operation, thank you to refer to the Getting started manual**

A History function has been added. This configuration software also can recover the «Buffer events» in a J3500, sort events recovered, see recurrences, safeguard PC, print them.

Panel n° : 1	Counter	Time	Channel	Parameter	Display
01	0000102	0:00:00.510	V03	Alarm	Blink Slow
02	0001543	0:00:07.715	ACK	Info	CL Acknowledge
03	0001543	0:00:07.715	V02	Alarm	Steady
04	0001544	0:00:07.720	V03	Alarm	Steady
05	0001545	0:00:07.725	ACK	Info	Clear
06	0001646	0:00:08.230	V02	Alarm	off

**Inputs**

No	Wdr	Order	Processing	Detection	Follow	Inhibit	To Output	To Alarm	Out of	Report
1	NO	0 0 0 20	Warning	Standard	No	No	1 0 0 0	Yes	Flashed	No
2	NO	0 0 0 20	Warning	Standard	No	No	2 0 0 0	Yes	Flashed	No
3	NO	0 0 0 20	Warning	Standard	No	No	3 0 0 0	Yes	Flashed	No
4	NO	0 0 0 20	Warning	Standard	No	No	4 0 0 0	Yes	Flashed	No
5	NO	0 0 0 20	Warning	Standard	No	No	5 0 0 0	Yes	Flashed	No
6	NO	0 0 0 20	Warning	Standard	No	No	6 0 0 0	Yes	Flashed	No
7	NO	0 0 0 20	Warning	Standard	No	No	7 0 0 0	Yes	Flashed	No
8	NO	0 0 0 20	Warning	Standard	No	No	8 0 0 0	Yes	Flashed	No
9	NO	0 0 0 20	Warning	Standard	No	No	9 0 0 0	Yes	Flashed	No
10	NO	0 0 0 20	Warning	Standard	No	No	10 0 0 0	Yes	Flashed	No
11	NO	0 0 0 20	Warning	Standard	No	No	11 0 0 0	Yes	Flashed	No
12	NO	0 0 0 20	Warning	Standard	No	No	12 0 0 0	Yes	Flashed	No

**Outputs**

Output	Equality	Mode	Disability
1	Deactivated	Permanent	Automatic
2	Deactivated	Permanent	Automatic
3	Deactivated	Permanent	Automatic
4	Deactivated	Permanent	Automatic
5	Deactivated	Permanent	Automatic
6	Deactivated	Permanent	Automatic
7	Deactivated	Permanent	Automatic
8	Deactivated	Permanent	Automatic
9	Deactivated	Permanent	Automatic
10	Deactivated	Permanent	Automatic
11	Deactivated	Permanent	Automatic
12	Deactivated	Permanent	Automatic

**General**

Inputs	Outputs	General	Communication
<input type="checkbox"/> Inhibit <input type="checkbox"/> Follow-up map <input type="checkbox"/> Alarm <input type="checkbox"/> Test <input type="checkbox"/> Point pushbutton activation	<input type="checkbox"/> Inhibit <input type="checkbox"/> Alarm <input type="checkbox"/> Test <input type="checkbox"/> Point pushbutton activation	Flasher delay: [ 10 ] [ 20 ] [ 30 ] [ 40 ] Inhibit delay: [ 10 ] [ 20 ] [ 30 ] [ 40 ] Alarm delay: [ 10 ] [ 20 ] [ 30 ] [ 40 ] Test delay: [ 10 ] [ 20 ] [ 30 ] [ 40 ] Point pushbutton activation: [ 10 ] [ 20 ] [ 30 ] [ 40 ]	Net type: [ RS485 ] Physical: [ RS485 ] Speed: [ 9600 ] Stop bit: [ 1 ] Parity: [ None ] Brightness setting: [ 100% ]

## PRODUCING LABELS :

Labels are ordinary paper sheets that can be slid into a transparent pocket included in the thickness of the front. A blank label is supplied with each unit.

Labels can be handmade, or produced on a color printer (Laser or ink-jet).

The PC software allows to create labels including images, allows to save and duplicate the achievements.

This PC software is FREE. It is possible to load it on our website :

[www.ami-control.com](http://www.ami-control.com)

For high humidity countries, the printing on plastic sheets is recommended.

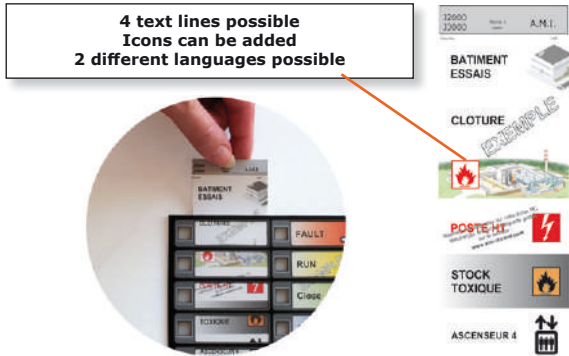

## CHANGING LEDS COLOUR :

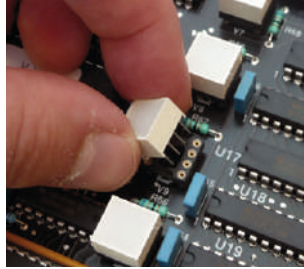

The LEDs are fitted on detachable sockets, enabling a change of colour. The colours available are the following ones :

**Red, Green, Yellow, Blue, White.**

The working lifetime of this component is practically unlimited. The low consumption (max 20mA per LED) and excellent luminosity contribute to the J3500 reliability.

## OPERATING PRINCIPLE :

The J3500 allows optimized information management. Each input can be treated in simple visualization (ON/OFF) or with alarm treatment. Each input contact (also those with simple visualization) can be selected normally open or normally closed. A filter on input by temporization (delay time) is present.

Simple visualization or simple display (ON/OFF) :

Processing for stable information but minor as On, Off, level, temperature, ...

One input in «simple visualization» is displayed in fixe (ON) long as input remains present without audible alarm, without RESET.

This input can activate one or more outputs and relay «Synthesis».

The loop control on the continuity of the input and the filtering time are possible.

Alarm :

Processing for dangerous information with emergency. Used in situation where it is necessary to call the operator (level and too high temperature, fire, trigger, ...).

The operator can be absent, information will be displayed blinking, memorized and the display will remain present until acknowledged by the operator.

This input can activate one or more outputs, relay «audible alarm» and «Synthesis» relay.

The loop control on the continuity of the input is possible.

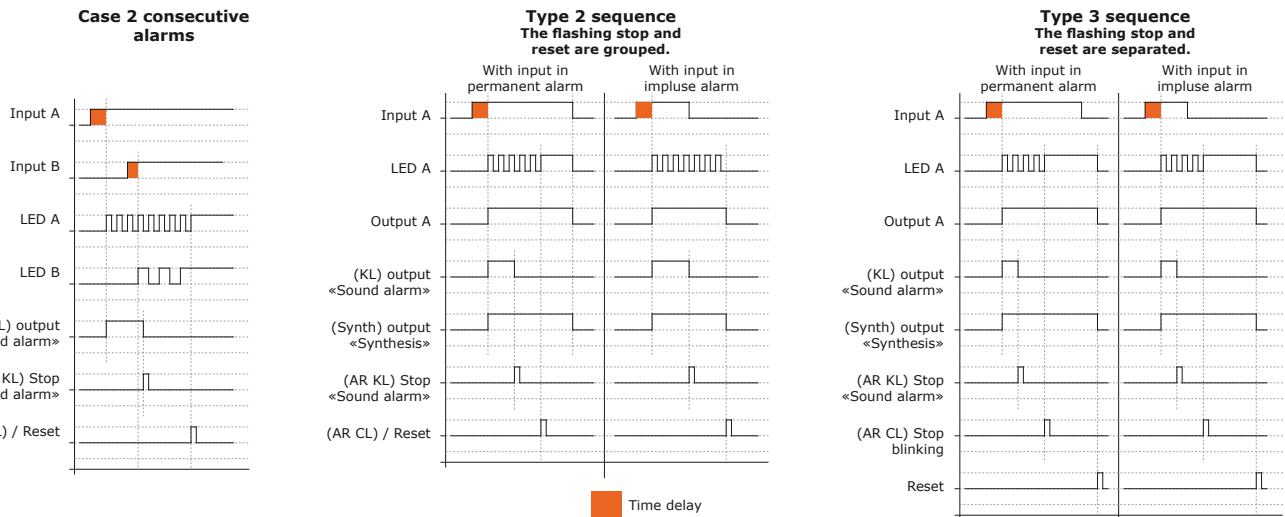

In diagram «Type 2 sequence» and «Type 3 sequence», the LEDs are represented in «fast blinking» mode.

The change of input state, after filtering time, causes LED blinking and the activation of sonorous output and synthesis output. This action will be stored even if the input disappears. The reset will be done step by step, after pressing the push buttons and depending of the sequence selected and the input position.

The first incoming alarm causes a display by a «rapid blink». The following lanes cause a «slow blink». This allows differentiating the first alarm among the followings. The cable defect will be displayed in «flash». The audible output is activated on each incoming alarm.

**For details of operation,  
thank you to refer to the Getting started manual**

## SETTING INPUTS :

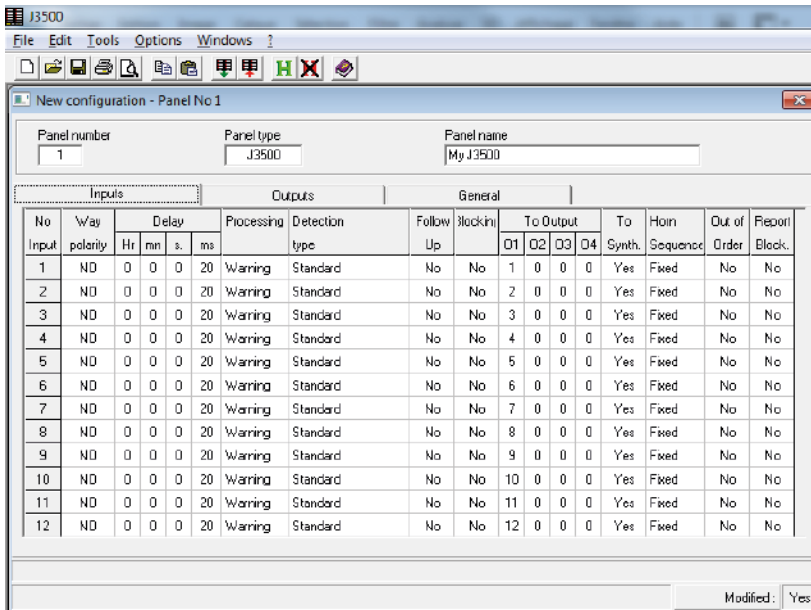

Input	Way	polarity	Delay				Processing	Detection type	Follow Up	block in
			Hr	mn	s	ms				
1	NO		0	0	20	Warning	Standard	No	No	
2	NO		0	0	20	Warning	Standard	No	No	
3	NC		0	0	20	Warning	Standard	No	No	
4	NO		0	0	20	Warning	Standard	No	No	
5	NO		0	0	20	Warning	Standard	No	No	
6	NO		0	0	20	Warning	Standard	No	No	
7	NO		0	0	20	Warning	Standard	No	No	

- Selecting input type (NO / NC)
- Temporization delay to filter this input: 20ms to 24h
- Input processing :  
- simple signaling or indicator  
- alarm
- Detection on input  
- Loop control (connection cut or shorted)  
- With RESET per channel
- Reactivation of alarm in case of operator's forgetfulness

Setting each input separately :

- **Direction of inputs** (Normally Open or Normally Closed).

- **Filter Delay on input** from 100ms to 23h 59mn 59s 900ms with 100ms increments.

- **Input treatment type** : Alarm or signaling (indicator).

- An input configured in alarm mode will be memorized, will activate the LED flashing, will activate the audible alarm and will wait for an RESET.

- A signaling input (Indicator) is simply displayed (ON / OFF).

The corresponding LED will be switched off with the disappearance of the input.

- **Input detection type** : Standard/Control loop.

- «Standard» is the normal configuration.

- «Loop control» Ensures effective control of the wire continuity on each input. Controls the short circuit or the cut of the cable between the J3500 and the contacts. Just put two resistors (one series and one in parallel) directly to the contact. This allows to continuously monitor the line current. A cable fault will be displayed blinking «flash» + audible alarm.

Only the «Audible alarm» will be acknowledged.

The output will not be activated.

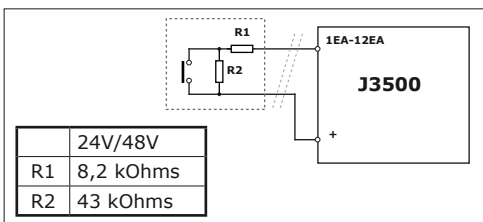

- **Reactivation of alarm** : Allows avoiding alarm information is forgotten by operator, allows the channel to be reactivated in alarm (audible and visual) after a certain time.

- **Blocking the channel (Inhibition)** : Inhibits temporarily the channel if the contact of inhibition input «Bloc» has been activated.

- **Outputs allocation** : Each input can activate up to 4 possible outputs that will be activated by the presence of this channel. Allows groups of specific inputs for sending remote syntheses. An input can control up to 4 outputs. This allows you to group remote information according to many levels. The output will remain activated as long as one of the causes having generated will remain present (the equivalent of an «OR»).

Example :

- The outputs «high risk».

- Alarms for the mechanic and alarms to the electrician.

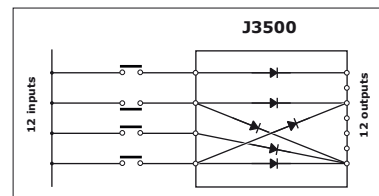

- **Enable to the synthesis relay** : The Way activate or not the synthesis relay.

- **Type audible sequence** : Selects 1 from 4 audible sequences which will be activated to the appearance of this channel. Allows better auditory discrimination according to the danger level of the incoming alarm.

- «Without» : The audible alarm is disabled.

- «Fixed» : The audio alarm is activated continuously until acknowledged.

- «One pulse» : The audible alarm is activated for 1s only making unnecessary audible acknowledgement.

- «T1/T2» : 2 types of sequences defined by the user.

Example : Indicator 1s / 1s and flashing 1s / 2s.

These two sequences require an audible acknowledgment.

- **Out of order** : Allows you to block (inhibit) a channel when the contact is incorrect operation. It will always be displayed on the LED but not audio alarm. When the contact will return to normal position, the LED will flash «Very Slow» to indicate this particular setting.

- **Blocking on out of order** : Allows to stop or not the activating of outputs when the channel is parametrized on «out of order».

**For details of operation,  
thank you to refer to the Getting started manual**

## SETTING OUTPUTS :

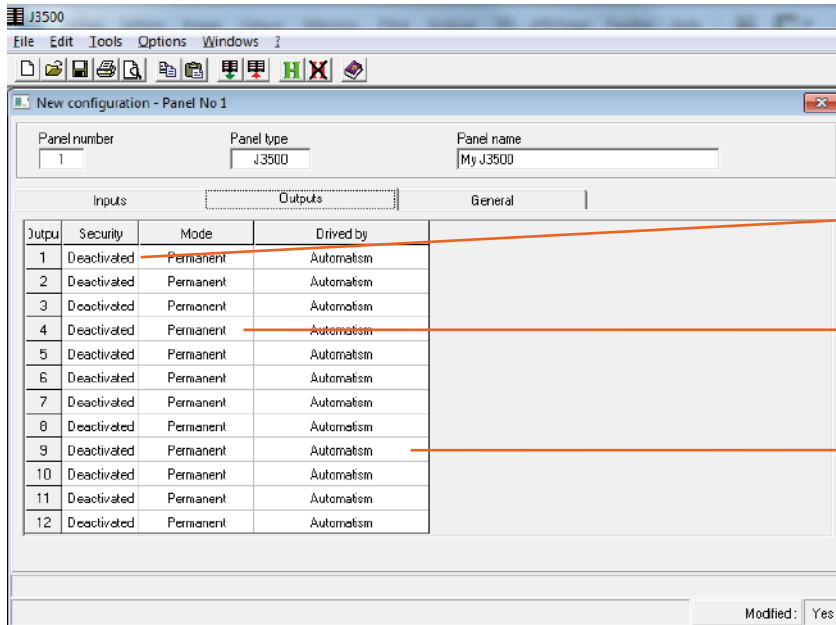

Setting each output separately :

- **Direction** : Outputs can be negative or positive safety.
- **Controlled by** : An output can be activated by :
  - The appearance of the input and follow the movements of this input.
  - The memorization of the input. (Up erasing the Led).
  - The Led state (and blink fast or slow like this one).

- **Software Version Prom V1.05I (on request):**

This version adds the pulse output function. The output will issue a pulse to the appearance of the way. This function is used to inform remote the arrival of a new alarm or the presence of an ever existing alarm.

The outputs will become «blinking», i.e., with the same state as the Led on the front (flash, fast or slow flashing, OFF). Can be used to pilot an external mimic. The «Led Test» function can activate the outputs directly (as on front LEDs).

- If input is a first fault.
- Special software for remote monitoring.

### Output controlled by :

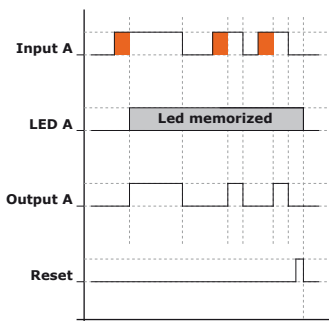

**«Input»** : This function is intended for remote maintenance. It allows a remote operator to know the return to normal and the arrival of a new alarm on an unacknowledged channel and to determine the level of intervention necessary. If the input is still present after the time delay, the output will be activated. If the input is impulsive and disappears, even if the channel is not acknowledged, the output will disappear. It will be reactivated if the input reappears (and after a timeout).

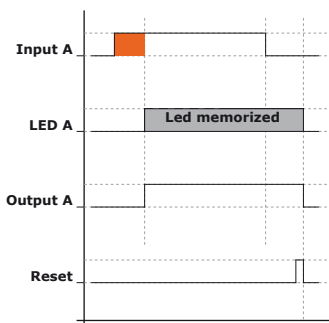

**«Input Memory» or «Automatism»** : The output is activated after filter time delay (when the LED is displayed) and will remain activated so long as the LED will remain visible on the front (the output follows the input memory).

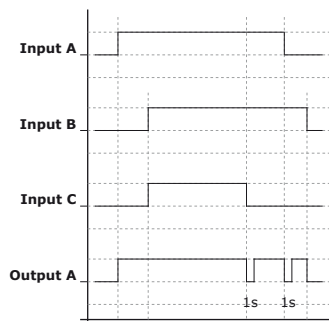

### «Input with Revival» :

An output can be activated by several inputs. This function allows reactivating the output to the appearance of a new input assigned to the same output. In this case, the output is switched off for 1s, and then reactivated.

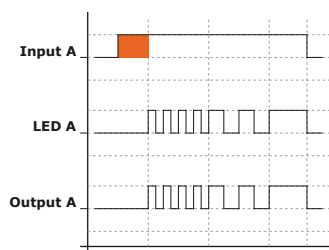

### «Front panel LED» or «Blinking» :

The output will be the exact image of LEDs of the facade with a rapid blinking, slow, fixed and OFF. This function is intended to control external lamps or external mimic (synoptic).

- **«1st fault»** : The output will only be activated if the input channel is a first default.
- **Remote watching** : function used in the case of remote monitoring station.

Time delay

For details of operation,  
thank you to refer to the Getting started manual

## GENERAL SETTING :

These settings affect the entire panel :

Communication by BUS  
RS485/RS232  
ModBus / Jbus

Different languages possible  
French  
French  
English

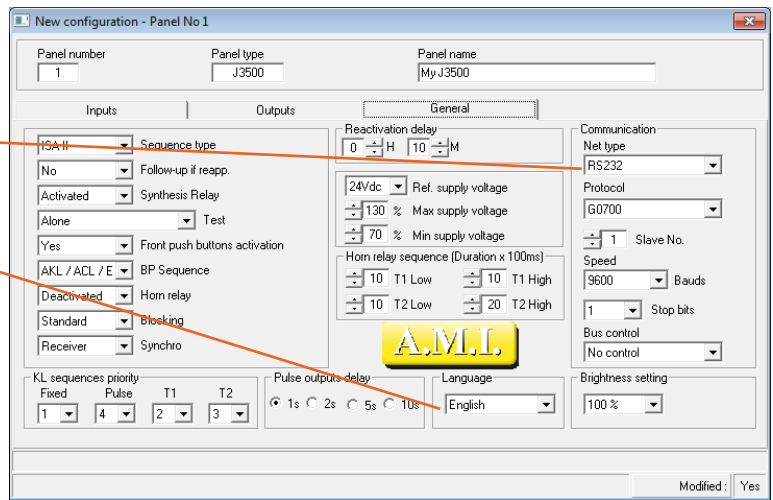

### - Type sequence : ISA2 / ISA3 / Slow Blink

- «ISA2» : Standard sequence. It is necessary to stop the audible alarm first. The LED will always be in blinking. After acknowledgment, the LED will become fixed (ON). Then the LED will turn off automatically return to normal of the input.
- «ISA3» : Similar with the precedent but after switching to LEDs fixed (ON), it will remain present after the return to normal of the input. Intentional RESET per operator will be needed to switch OFF the LED. (First possible defect, possible loop control).
- «Slow Blink» : Sequence similar to ISA3. On arrival of the alarm, the display is done by flashing (fast or slow). After the stop «audible alarm», LED becomes fixed. When the input returns to the normal state, the LED will flash slowly indicating to the operator that it can erase. Displaying the «loop control» possible, impossible to display the «first fault».

- **Follow-up if reappearance** : A channel can be in alarm, displayed «acknowledged» or not and waiting to return to normal and waiting to operator «RESET». In the case of an alarm that would disappear and reappearing, the signaling and audible alarm will be reactivated.

- **Synthesis relay** : It can be activated normally (positive safety) or not.

- **«LED Test» Mode** : The «LEDs Test» button can have several actions :
  - «Alone» performs a «LED test» only on the front panel LEDs.
  - «LEDs With Output» tests the LEDs on front panel and outputs (used when the outputs animate a mimic in flashing mode).
  - «LEDs With KL» tests the LEDs on front panel and audible alarm.
  - «LEDs + Output + KL» : tests the LEDs on front panel, outputs and audible alarm.

- **Front push buttons** : (YES/NO). Allows the inhibition of the front push buttons when using external buttons connected on rear terminals.

- **BP sequence** : Regrouping functions «audible alarm OFF» and «blinking Off».
  - «AKL/ACL/EFF» : Separation of functions «Audible alarm», Acknowledgement (blinking off), Erase (reset).  
Front panel buttons : two successive presses in ISA2, 3 successive presses in ISA3.  
Buttons deported : 2 external buttons in ISA2, 3 external buttons in ISA3.
  - «AKL+ACL/EFF» : Regrouping functions «Audible alarm» and acknowledgment (blinking Off).  
Front panel buttons: 1 single press in ISA2, 2 successive presses in ISA3.  
Buttons deported : 1 single external button in ISA2, 2 external buttons ISA3.

- **Horn Relay** : Audible alarm relay can be activated normally (positive safety) or not.

- **Blocking** : Defines how the inhibition function will be realized when an alarm is present in display.

- **Synchro** : Allows you to set the panel in transmitter or receiver of sync tops. The synchronization of the blinks of LEDs of several J3500 facing an operator, increases visual comfort.

- **KL sequences priority** : Assign an order priority to the 4 types of sound alarms. This priority allows define what type of sound sequence will be executed first. If two alarms occur simultaneously, the audible output will be activated with the smallest priority level. This function allows you to manage the degree of urgency by a audible discrimination.

- **Reactivation delay** : 0 to 23h. Adjusts the time to reactivate the display if an acknowledged alarm is still present.

- **Supply voltage** : The panel is equipped with a voltage level control . Adjusts the under voltage and overvoltage threshold level in % of the specified voltage.  
Possible values: 24Vdc, 24Vac, 48Vdc.  
If the threshold is exceeded, an alarm will be displayed in the text screen and the red LED on the front (item 4 on the Front view ).  
The J3500-04-xx version (80-260Vac /dc) is equipped with a stabilized switching power supply. The control is not possible for the values (110Vac, 125Vdc, 200VDC, 220Vac).

- **Horn relay sequence T1/T2** : You can adjust the duration ON / OFF of flasher relay audible alarm. 2 possible flashing types (one fast and one slow).

- **Language** : Allows language selection on the J3500 screen.

- **Network Type** : Selects connection type on port «BUS»: RS232 / RS485 with 4 wires / RS485 with 2 wires.

- **Protocol / number slave / Baud Rate / Stop bits.**

- **BUS control** : Active and adjusts the temporization of presence control security on the bus.

- **Brightness** : Adjusts by program the LEDs brightness.

- **Prom V1.05I Version** : This version adds the following parameter :
  - Adjusting the length of the pulses on the outputs.

## LEDS FUNCTION :

«Pavers LEDs» type, they have very high contrast between «ON» and «OFF» position. Being unpluggable, it is possible to change the color.

Fault avalanche :

The differentiation between the 1st fault (first alarm) and the 2nd is done by flash and slow blink (1st fault is displayed in fast flashing mode; the following alarms are displayed in slow blink mode).

The avalanche is an arrival of several consecutive alarms.

It is very important to know the first alarm, as this enables rapid intervention in troubleshooting.

The avalanche begins with the arrival of the first alarm until operator cancellation. After cancellation by operator (all flashing LEDs are become fixed), a new alarm will be considered as a first fault.

Discrimination time: 10ms.

The various light states on the LEDs :

**Fast blink** = 1st alarm.

**Slow blink** = following alarm in avalanche.

**Very Slow blink** = return to normal position of contact in «Out of order» mode.

**Fixed light (ON)** = alarm present, memorized after acknowledgement.

**OFF** = return to normal state

**Very fast Flashing** = cable fault (this luminous signal is not cancellable).

## REPRESENTATIVE DIAGRAM :

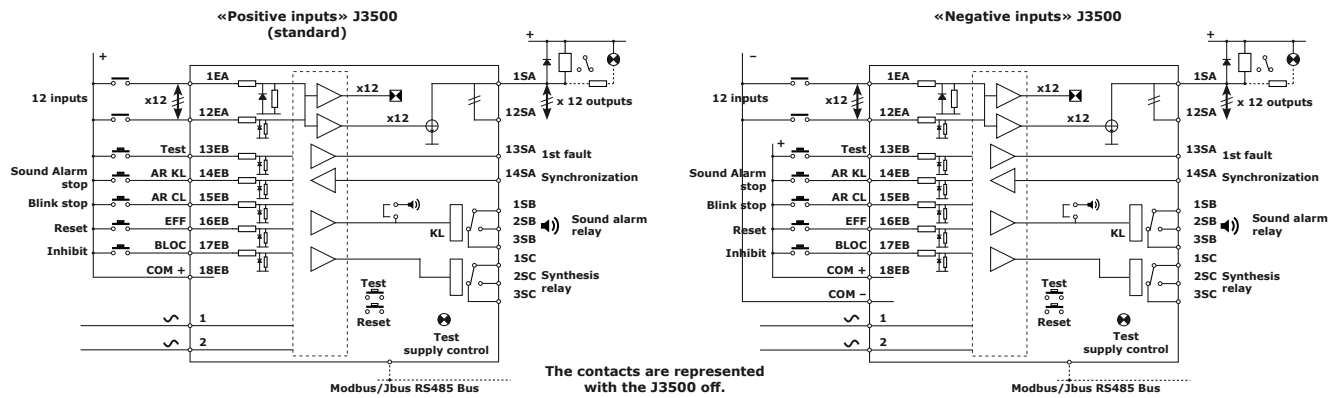

- The inputs are called «positives» when the common feeding the alarm contacts is connected to «+».  
 - The inputs are called «negatives» when the common feeding the alarm contacts is connected to «0V».

## TEXT DISPLAY FUNCTION :

Display of 2 lines of 16 characters, it displays :

- The operating status of the panel and these alarms with No. of input and type alarm, supply voltage control alarms, continuity of control over inputs.
  - The historical ranked in order of arrival of the 64 last states informations with number of the channel. It also allows erase the history buffer.
  - The various configuration settings.
- 3 front panel buttons are used to select various functions and to access the setup menu via an access code.

## FUNCTION OF FRONT FACE BUTTONS :

The front is equipped with three buttons : «Test leds», «RESET» et «Paramétrage».

RESET combines several functions :

1st press => Stop Horn / 2nd press => Flashing off / 3rd press => Erase

The flash off (switching to fixed lights) will be processed only if the alarm has been stopped.

The «program» button is used in combination with the «test» button or the «Reset» button only in the program mode.

(See also the «**FUNCTION OF REAR TERMINALS**» and the start-up instructions of the J3500).

## INPUT FUNCTION :

Terminals 1A / 12A : The 12 contact inputs can be «Positive common» or «Negative common».

A direction of operation (NO/NC) and a delaying time may be associated to each input.

Channel validation is effective only if the channel remains in alarm state for duration greater than the selected delaying time.

## FUNCTION OF REAR TERMINALS AND FRONT FACE BUTTONS :

The terminals (TEST + KL + AR CL + RESET/EFF + BLOC) will always be connected to external contacts supplied with a positive polarity. (Preferably the «+Com» terminal).

TEST terminal 13EB : This is a «LEDs Test» program activated by the micro-controller.

Ability to perform the test to : LEDs, outputs / Relay «Audible alarm».

This terminal also can remotely set the luminosity.

This input (with terminal 15EB) also allows the activation of the self-test (see «special functions»).

The order of use of the 3 following terminals must be respected.

The terminals AR CL and EFF are inactive if the audible alarm is present. In sequence type 3, the EFF terminal is inactive if a LED blinks (no RESET possible before stop blink).

AR KL terminal 14EB (Audible alarm stop) or button front face «RESET/Horn Stop » first impulse :

Standard function: An input activation on 14EB stops the audible alarm until the return to normal state of input.

By program, it is possible to group the terminal AR KL and AR CL, In this case, a single external button connected to terminal AR CL, will stop the audible alarm and stop the blinking on the LED.

AR CL terminal 15EB (blinking stop) or button front face «RESET/Horn Stop » second impulse : One activation changes the flashing mode to fixed mode (only after you have stopped the alarm sound).

Functioning type 2 sequence : When alarm will disappear, LEDs in fixed mode (ON) will switch OFF (After an activation on AR CL, if an input returns to normal, the blinking LED goes to fixed and quickly turns OFF.

Functioning type 3 sequence : With this sequence, activation on AR CL terminal also turns ON the LED (fixe). But when the alarm will disappear, it will be necessary to use the EFF terminal to cancel the fixed light (turn OFF).

Auto-test sequence: (TEST + AR CL terminals or the 2 front push buttons).

If an operator presses and maintains the 2 push buttons or if the 2 terminals are activated simultaneously, the internal test cycle starts (LEDs Test + 2s + horn relay test + 2s + synthesis relay test + activation of all outputs). This test is an «incremental» type which activates the each channel, each output, one after the other, and the selected outputs («Synthesis» relay, «Sound alarm» relay).

This is a chaser lights type. it activates the LEDs , one after the other, and selected outputs (outputs, relay «Synthesis», relay «audible alarm»).

RESET/EFF terminal 16EB (RESET) or button front face «RESET/Horn Stop » third impulse :

- Functioning type 2 sequence: RESET/EFF this terminal is not used.

- Functioning type 3 sequence: The LEDs will turn OFF only after switching to fixed mode and after the input will be returned to normal, when the RESET/EFF terminal (or after the third impulse on the RESET front button) will be activated.

Bloc or Inhibition terminal 17EB : The channel inhibition is activated by connecting a «+» on «Inhibition» input. The selected inputs in «Blocking» will no longer be recognized as long as the inhibition input is activated. One selected input is active only if the inhibit input is inactivated.

If a selected channel inhibited is already displayed before the activation of the terminal block (17EB), the display management will continue until its extinction (return to normal of the channel input).

For inhibition, the channel must be selected in parameters AND the terminal 17EB must be activated BEFORE the input change.

This function is an indefinite temporization equal to the duration of activation of the terminal 17EB.

«+COM» terminal 18EB : the «COM+» terminal allows supplying the input contacts with correct voltage and with internal protection. However, these inputs can be supplied with the «+» of the supply voltage only for J3500-02 -xx version.

## OUTPUTS FUNCTION :

### Terminal 1SA/12SA : 12 outputs

The panel has 12 electronic outputs 150mA. This output transmits a «0V» (collector open). The external receiver should be connected to «+» (maximum voltage: +48Vdc). In certain cases it needs to be protected against break surges and against cold start currents (bulb with filament) by the use of a serial low resistor. These outputs are enabled or disabled at the onset of input activation or the LED. This is depending on the setup.

There are different relay output interfaces with galvanic isolation (optional). They ensure optimum and fast operation without the risk of destruction. (Refer to chapter «Accessories»).

For all possible functions with outputs, refer to § output settings and start-up instructions).

### 1st fault terminal 13SA : (Terminal in Input/Output mode).

Used to group multiple panels to get the 1st fault sequence on all channels.

If a panel has a first alarm displayed, it changes the status of its terminal 13SA which will be received by the other connected panels.

When the other panels will receive an alarm, they will display in slow blinking mode.

The power supply of this terminal is specific to this panel (never connect other function than the «1st fault » terminal of another panel).

### Synchro terminal 14SA : (Terminal in Input/Output mode).

It synchronizes the blinking between all panels connected.

If several flashing alarms are present on various panels, this can lead to visual fatigue for the operator.

All panels with flashing LEDs will be synchronized on the signal coming from this terminal.

- If synchronization is not selected on the panel (transmitter), it is master and transmits timing clock pulses to the other users (it synchronizes itself on its own pulses).

- If synchronization is selected on this panel (receiver), it receives pulses coming from outside and synchronizes on them. In the unlikely event of connection failure, the panel would resume its own synchronization.

The power supply of this terminal is specific to this panel (never connect other function than the «Synchro» terminal of another panel).

**1SB/2SB/3SB terminals :** Outputs inverter contacts of audible relay.

**1SC/2SC/3SC terminals :** Outputs inverter contacts of synthesis relay (general alarm relay).

## CONNECTIONS :

### Application example :

- Panels «1», «2», «3» are connected with contacts on their inputs which can be NO or NC selection.
- The «Test», «AR KL», «AR CL» and «EFF/Reset» are centralized for the three panels.
- Contacts «Synthesis» of each panel are connected in series to send remote information. Synthesis relays are parameterized in positive safety (relays normally activated).
- Audible alarm relays are selected in positive safety. Contacts are connected in parallel to an external general sound alarm).

- The blinking of the LEDs of this three panels is synchronized by the connection of the terminal 14SA. One of the panels has been set in «Transmitter», the others in «receiver» mode.
- Panels «1» and «2» are grouped to obtain the 1st fault among 24 inputs.
- The panel «3» uses its outputs directly to activate relays or external lamps. (Terminals 1SA and 12SA). A diode or resistor has been fitted as protection. The maximum voltage on outputs is 48Vdc only.

But other configurations are possible.

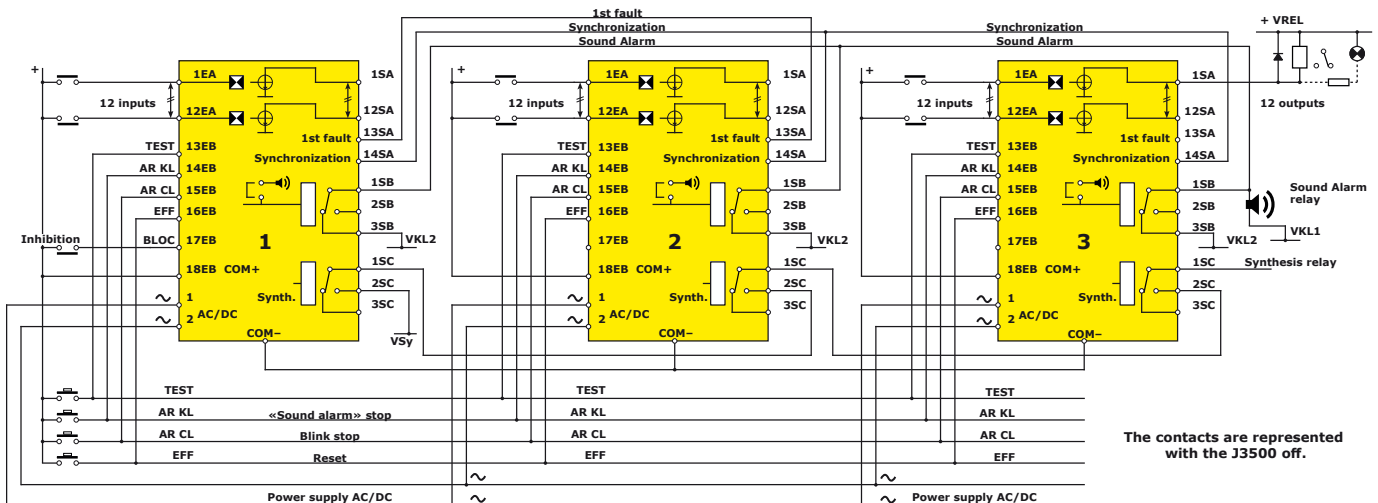

**+VREL :** supply voltage on the outputs. This external voltage (+48Vdc max.) is useful only for particular connection. (Our relay cards are supplied directly by the panel).

**VKL :** May be voltage independent of J3500 for supply the external «horn» with galvanic isolation. For example: 230Vac.

**VSy :** May be voltage independent of J3500 for supply the relay Synthesis contact with galvanic isolation. For example: 230Vac.

- «COM+» terminal (18EB) is used to supply the input contacts.

- With the 14-65Vac/dc, it is possible to use the polarity «+» of the J3500 power to supply all input contacts of several J3000.

**In this case, DO NOT CONNECT the «COM+»**



## PROGRAM EXTENSION : VERSION 1.05I PROM (ON REQUEST)

New software can be added to J3500, allowing the setting in adjustable pulse on outputs. This new function associated with the possibilities of the J3500 allows multiple possibilities.

To manage remote installations, it is often necessary to know :

- If an alarm is present,
  - If a new alarm occurs,
  - What is the danger level of the alarm present or incoming ?
- But it is also necessary to limit the number of wired connections.

This function will help to decide whether an intervention is immediately necessary or whether it can be postponed.

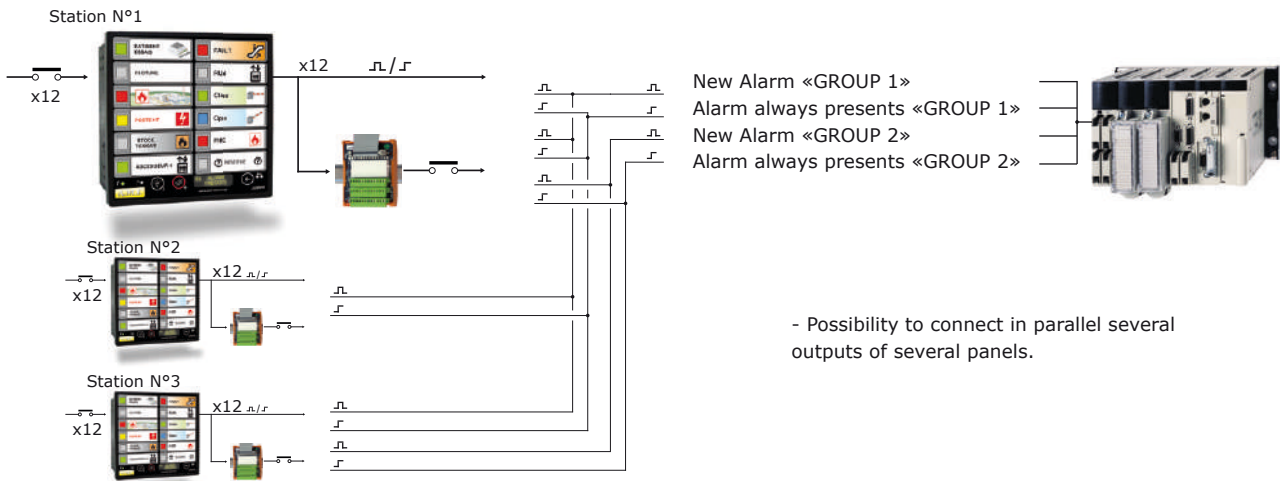

## SEND ALARM INFORMATION TO PLC REMOTED :

- Several levels of alarms: the J3500 allows creating different levels of alarms and group outings per family depending on their level of alarm.
- «New alarm» output delivering a pulse each new arrival on a change in a family input.
- «Alarms always present» output delivering a permanent state as long as inputs related to the family are present.

Regrouping outputs from different inputs :

It is possible with the J3500 to sort and regroup each of alarms present on 4 different outputs among 12 as desired.

This allows categorize them by families and / or by danger level.

It becomes possible with an external PLC to know the arrival of a new alarm or family of alarms (output pulsed), whether an alarm or family of alarms is still present and with what level of alarm (permanent output).

Example : To supervise : Electrical alarms, gas alarms and temperatures alarms. Each with several degrees of emergencies. Many other combinations are possible.

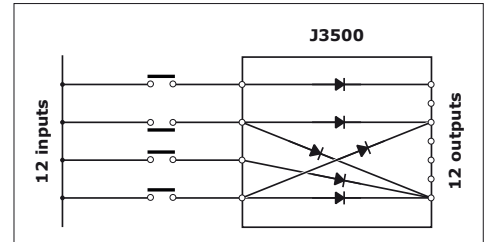

### PERMANENT OUTPUT :

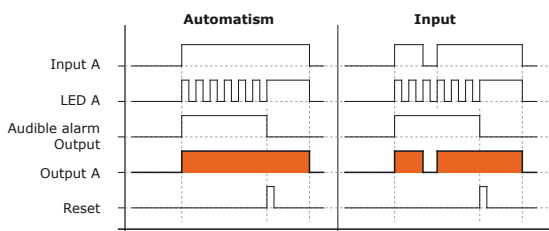

Allows to remote signaling the presence of an ever existing Alarm.

- Ability to set outputs «permanent» (alarm always present). They will issue a permanent state as long as one of the associated inputs is present. They issue a Permanent state as long as one of the associated entries is present.
- Ability to set the operation of the output:
  - «INPUT» mode (depending on the physical input). The output is activated if the input is present.
  - In «AUTOMATISM» mode (depending on the LED). The output is activated by the presence of the display of LED (input present or not).

### ADJUSTABLE PULSE ON OUTPUT :

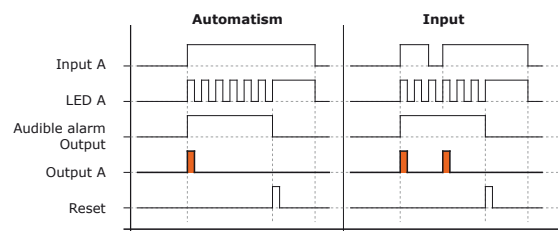

Allows to remote signaling the arrival of a new Alarm.

- Ability to define outputs «impulse» (new alarm) with adjustable pulse length. They will issue either one single pulse, or 1 pulse to each input arrival associated with this output.
- Ability to set the functioning output with «INPUT» mode (depending on the physical input) or «AUTOMATIC» mode (depending on the display present or not). This pulse can be generated by :
  - The presence of the LED display (1 single pulse until the next RESET, even if the input disappears and then returns)
  - The presence of the input (more pulses if the input disappears and returns).

All these features make the J3500 a very powerful local alarm display

## SPECIFICATIONS :

Minimum voltage supply (when using relay cards)	17Vdc
Maximum consumption	500mA/24Vdc, 256mA/48Vdc 116mA/110Vdc, 130mA/230Vac
Minimum consumption	100mA/24V
Temperature (at nominal voltage)	-10°C / +50°C
Relay contact	1RT 6A/12Vdc - 0,15A/240Vac
weight	750g
Dimensions	144 x 144 x 65 mm
Without protection cover	IP52
With protection cover	IP54

Possible voltages	14Vdc-65Vdc, 14Vac-49Vac, 80Vac/dc-260Vac/dc
12 «open collector» outputs	according to supply voltage (see output interface)
Current by output	150mA
Input current	2,4mA
Permitted line resistance on input	2 kOhms
Time delay accuracy	+/- 20%
Discrimination between 1st and 2nd fault	10ms

## CUT-OUT :

DIN 144x144 format

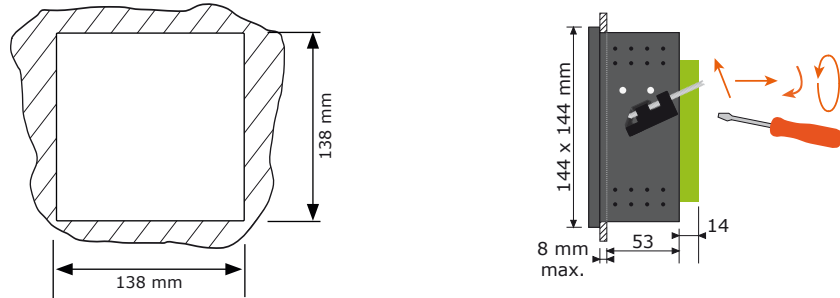

## Numbering system

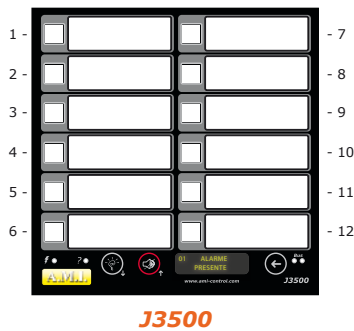

J3500

## REAR VIEW :

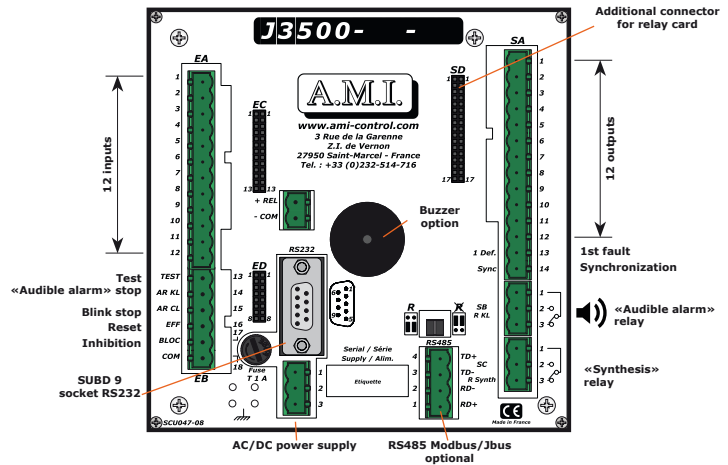

### Output ports :

- The RS232 port subD / 9 pins type for setting with PC is present as standard.

Ask the RS232 / USB adapter.

- Option: Port RS485 / 422 Bus connection with MODBUS / JBUS .

## ORDER REFERENCES :

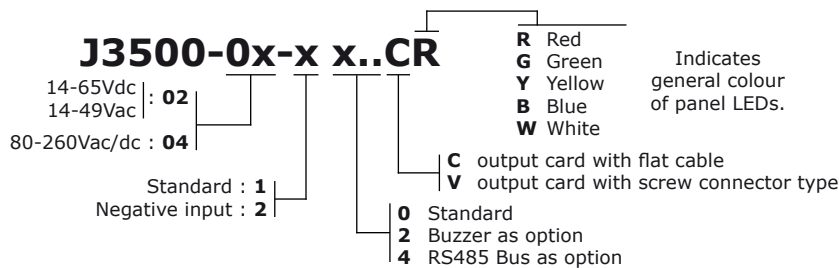

If multiple options, indices are placed in ascending order.

Example :

J3500-02-124CR  
J3500-04-10VR

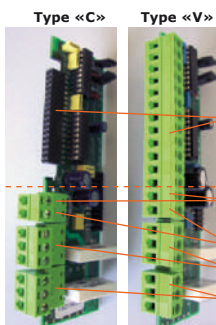

### Output Card : 2 models :

- Type «C» : With ribbon SD connector to connect a DIN additional card.

- Type «V» : With screw connector on the 12 outputs.

All other connectors are «screw-pluggable»..

Delivered with red LEDs as standard (Other models on request).

### Possible complementary LEDs :

J2001-00-00	LED 10x10mm colour GREEN, code : 2855
J2001-00-10	LED 10x10mm colour YELLOW, code : 2755
J2001-00-20	LED 10x10mm colour RED, code : 2655
J2001-00-30	LED 10x10mm colour BLUE, code : 2655MBW
J2001-00-40	LED 10x10mm colour WHITE.

## **ADDITIONAL PRODUCTS :**

**M0800 Front plate 19-inch, brushed aluminium Ht : 4U**  
Front for bay 3 pre-drilled holes 138x138mm.

**M0815 Closing cover**  
Closing cover for mounting on M0800 front plate.



**M0800  
M0815**

### **M0720, IP54 sealed front**

«Quarter-turn» closing button  
DIN format 144x144.  
IP54 sealed front that is fitted directly to product front.  
An O-ring provides sealing between steel cabinet and panel.  
The front is a transparent opening door..



**M0720**

## **EXTENSION RELAY CARDS WITH GALVANIC ISOLATION :**

Equipped with relays these cards deliver a dry changeover contact (without voltage) with galvanic isolation for each output. These cards allow secure use of «open collector» outputs with maximum safety.  
The relays are powered directly through the panel.

- Contacts feature: 1RT 6A/24Vdc or 48Vdc - 0,15A/240Vac
- A LED on each relay displays its state.
- 3 removable terminal blocks are available (one for contacts «O», one for contacts «F», the last for common).
- DIN rail bracket at the bottom of cabinet. With quick connection to the panel by ribbon cable.  
They avoid too many wires on the cabinet door.

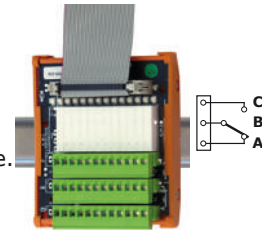

These cards are available in versions :

- 12 relays changeover contact each (there are as many relays as there are outputs).  
**M0901-02-01** Card 12 relays 24Vdc to fit to DIN rail (For J3500 supplied with any voltage except 48Vac/dc).  
**M0901-03-01** Card 12 relays 48Vdc to fit to DIN rail. (For J3500 supplied with 48Vac/dc).

- 2 relays 1RT type with selectors; it allows you to sort the outputs in two directions :  
Electrician / mechanic or Alarm high risk / Alarm ordinary.  
**M0901-02-20** Card 2-synthesis-relays 24Vdc to fit to DIN rail.  
Panel supply minimum voltage: 17Vdc

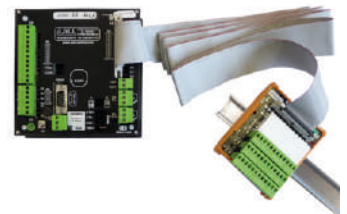

Don't forget the cable connection :

- M0901-02-50** Ribbon cable L=1.5m fitted for one relay card.
- M0901-02-51** Ribbon cable L=1.75m fitted for two relay cards.
- M0901-02-52** Ribbon cable L=2m fitted for three relay cards.
- M0901-02-55** Additional length L=0,5m.

### **M0730 Adapter to mount on DIN Rail profil TS35.**

144x144 format  
This kit allows to mount panels with 144x144 format on a DIN rail TS35 retaining the display towards the operator.



### **G0100-05-30 RS232 / USB adapter for setting with PC**

This adapter enables the connection between the J3500 and a PC equipped with a USB plug. it connects directly to the RS232 cable supplied with the J3500.



### **KJ3500-1 Demo Kit,**

includes :

- 1 card equipped with 12 inputs contact by switches, 4 push buttons («Test LEDs», «stop horn», «Flashing Off / Reset», «Erase»), 1 switch «Blocking» 1 Jack diet.
- 2 cards Output (one with screw connector, the other with flat cable connector) equipped with 12 LEDs for outputs, 2 LEDs for output «Synchro» and «first Fault », 2 LEDs for output contact «Synthesis», 2 LEDs the contact output «Audible alarm» 1 Buzzer.
- 1 adaptator supply 230Vac / 24Vdc power supply output jack.
- 1 operating manual connection and using.

**The test kit do not understand the product itself**  
only J3500-02, version 24V.

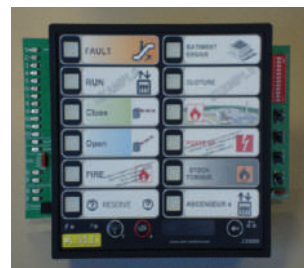

Demonstration kit

Refer to chapter ACCESSORIES from our catalog

## THE "HISTORICAL" MEMORY :

By using the RS232 port or the RS422/485 port (if the option is present), it is possible with a PC or an automaton, to recover the «history» buffer, to print it or to archive it. Free software is available on our site.

**The «history» buffer :** A history buffer memorises the last 64 events occurring on the panel :

event appearance with the type of display of the front LED (fast or slow blinking, fixed, off), the operator acknowledgement, and disappearance. The display types are :

- Fast blinking => arrival of a 1st fault.
- Slow blinking => arrival of next faults.
- Fixed light => arrival of simple signal (like states) or fixed light after an acknowledgement.
- LED off => return to normal.

The buffer is of the «FIFO» type, memorized by internal battery.

The stored information includes :

number of events stored, channel and panel number, type of hardware installed, type of channel setting, type of front panel display, J3105 internal counter value, allowing dating.

For more details,  
see transmission notice

N° Evt	Compleur	Temps	Voie	Paramètre	Affichage
01	000001	0:00:00.005	Y11	Alarme	Eteint
02	000001	0:00:00.005	Y12	Alarme	Eteint
03	000001	0:00:00.005	Y01	Alarme	Eteint
04	000001	0:00:00.005	Y02	Alarme	Eteint
05	000001	0:00:00.005	Y03	Alarme	Eteint
06	000001	0:00:00.005	Y04	Alarme	Eteint
07	000001	0:00:00.005	Y05	Alarme	Eteint
08	000001	0:00:00.005	Y06	Alarme	Eteint
09	000001	0:00:00.005	Y07	Alarme	Eteint
10	000001	0:00:00.005	Y08	Alarme	Eteint
11	000001	0:00:00.005	Y09	Alarme	Eteint
12	000001	0:00:00.005	Y10	Alarme	Eteint
13	0000102	0:00:00.510	Y11	Alarme	Clignotant lert
14	0000102	0:00:00.510	Y12	Alarme	Clignotant lert

## J3000 RS485 BUS VERSION, PROTOCOL MODBUS/JBUS :

**BUS option: product reference: J3500-xx-x4**



Please, ask us.  
the protocol transmission documentation  
for more information on signal frames.

**With the internal functions of the J3500 and by using a PC or a PLC, it becomes very easy to create your own centralization.**

**Just write a simple program using the language you know**

The J3500 panel is a controller to technical alarm that can be fitted with an RS485 type BUS link (2 or 4 wires).

It is a multi-task intelligent peripheral. It is working in degraded mode. In case of bus failure or when stopping the supervisor, the panels will continue their control and will display alarms.

It is possible to connect 64 panels on the same Bus.

- The supervisor can recover the local process information stored in the panel (status, alarms, histories).
- The supervisor can also send an sound and visual information to a remote operator by activating a channel through the Bus on a J3000/J3105 or J3500 panel. This information can come from the supervisor (from its internal management system) but it can also come from another panel and be sent to a «receiver» panel.

## COMPLETE TECHNICAL ALARM CENTRALISATION :

The PANEL'PC is an alarm centralizer on a RS485 Bus.

It can manage 64 panels with 12 alarms each.

Its touch screen allows to perform all necessary operations without additional keyboard (RESET, operator assistance display, historics, archiving).

It may refer alarms and remote information to other sub-stations.

It can be used either in a sub-station or control room :

- In local sub-station front cabinet, for monitoring alarms and local states, with historic for traceability.
- In control room with clustering by bus of local alarms panels.
- Possible transfer to other sub-stations.

## PANEL'PC :



RS485 Bus / 1 km / fitted with 64 modules as a maximum

**It is possible to very simply constitute a bus assembly for the management of technical alarms.**

- Possibility of using modules interchangeably:
- J3500/J3000/J3105 Automated technical alarm panel.
- J2x05RS signaling receiver panel with 12 or 24 LEDs.
- PANEL'PC.

The PANEL'PC integrates :

- Alarm display with «RESET» directly on the screen.
- Operator assistance or instructions for each inputs indicating to operator how to proceed depending on the alarm present.
- Display of historic periods.
- Re-display of the historic of a recorded period (10,000 pages possible).
- Printing in continuous with time stamping.
- Remote alarm reporting to one or several indicators display by BUS(for example, guard posts, technical service, control room).
- Remote outputs possible.
- Archiving on USB key.
- Login with several safety levels.

3, Rue de la Garenne - Z.I. de Vernon  
27950 SAINT MARCEL - FRANCE  
tél. : +33 (0)2 32 51 47 16  
Fax : +33 (0)2 32 21 13 73  
<http://www.ami-control.com>  
✉ : [contact@ami-control.com](mailto:contact@ami-control.com)

